

ZIRKULARFRÄSER TZ18

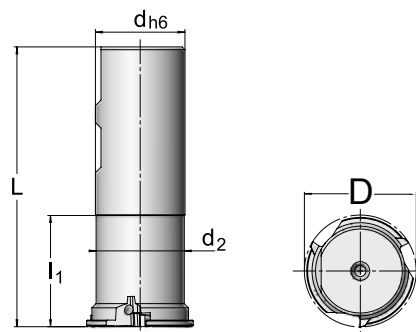

Standard für alle Seegerringnuten
 Dreiseitige Einbettung der
 Zirkular-Wendeschneidplatte
 Ideal für Nutbodenbearbeitung



TZ18 Schaftfräser										WSP
Artikel	D	d ₂	d _{h6}	L	l ₁	z _{eff}	a _e	lk	kg	
13T.2510.001	25	20,5	25	100	40	3	1,4 - 2,2	ja	0,31	TC..1103.R
13T.4011.001	40	31,5	32	100	39	3	2,2 - 3,2	ja	0,61	TN..1604.R

Daten WSP				
Artikel	D	s	B ^{H13}	a _e
TC.1103.030.06 SKY77	6,35	3,20	1,60	1,40
TC.1103.030.05 SKY77	6,35	3,20	1,85	1,70
TC.1103.030.04 SKY77	6,35	3,20	2,15	2,00
TC.1103.030.03 SKY77	6,35	3,20	2,65	2,20
TN.1604.018.01 SKY77	9,52	4,76	2,65	2,20
TN.1604.018.02 SKY77	9,52	4,76	3,15	2,20
TN.1604.018.03 SKY77	9,52	4,76	4,15	3,20

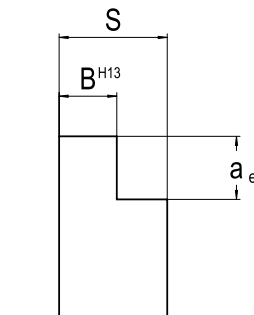

WSP-FORM TC | TN

		TC TN			
AS	Ø	s			
3	11	16	03	04	
	6,35	9,52	3,2	4,76	

Zuteilung Zerspanparameter
zu den AV Materialgruppen

				Stahl						
Artikel		Bezeichnung		A22	A21	A20	A19	A18	A17	A16
TC..1103..	TC.1103.030.06 SKY77	TCAX 110316 TR-25	h_{max}	0,12	0,10	0,08	0,07	0,06	0,05	0,05
			v_c	280-320	240-280	210-240	180-210	140-180	110-140	80-110
	TC.1103.030.05 SKY77	TCAX 110318 TR-25	h_{max}	0,12	0,10	0,08	0,07	0,06	0,05	0,05
			v_c	280-320	240-280	210-240	180-210	140-180	110-140	80-110
	TC.1103.030.04 SKY77	TCAX 110321 TR-25	h_{max}	0,12	0,10	0,08	0,07	0,06	0,05	0,05
			v_c	280-320	240-280	210-240	180-210	140-180	110-140	80-110
	TC.1103.030.03 SKY77	TCAX 110326 TR-25	h_{max}	0,12	0,10	0,08	0,07	0,06	0,05	0,05
			v_c	280-320	240-280	210-240	180-210	140-180	110-140	80-110
TN..1604..	TN.1604.018.01 SKY77	TNAX 160426 TR-25	h_{max}	0,15	0,12	0,10	0,09	0,08	0,07	0,06
			v_c	280-320	240-280	210-240	180-210	140-180	110-140	80-110
	TN.1604.018.02 SKY77	TNAX 160432 TR-25	h_{max}	0,15	0,12	0,10	0,09	0,08	0,07	0,06
			v_c	280-320	240-280	210-240	180-210	140-180	110-140	80-110
	TN.1604.018.03 SKY77	TNAX 160441 TR-25	h_{max}	0,15	0,12	0,10	0,09	0,08	0,07	0,06
			v_c	280-320	240-280	210-240	180-210	140-180	110-140	80-110

				Guss					
Artikel		Bezeichnung		D21	D20	D19	D18	D17	D16
TC..1103..	TC.1103.030.06 SKY77	TCAX 110316 TR-25	h_{max}	0,13	0,10	0,08	0,08	0,06	0,06
			v_c	340-380	280-340	240-280	210-240	180-210	140-180
	TC.1103.030.05 SKY77	TCAX 110318 TR-25	h_{max}	0,13	0,10	0,08	0,08	0,06	0,06
			v_c	340-380	280-340	240-280	210-240	180-210	140-180
	TC.1103.030.04 SKY77	TCAX 110321 TR-25	h_{max}	0,13	0,10	0,08	0,08	0,06	0,06
			v_c	340-380	280-340	240-280	210-240	180-210	140-180
	TC.1103.030.03 SKY77	TCAX 110326 TR-25	h_{max}	0,13	0,10	0,08	0,08	0,06	0,06
			v_c	340-380	280-340	240-280	210-240	180-210	140-180
TN..1604..	TN.1604.018.01 SKY77	TNAX 160426 TR-25	h_{max}	0,15	0,12	0,10	0,10	0,08	0,08
			v_c	340-380	280-340	240-280	210-240	180-210	140-180
	TN.1604.018.02 SKY77	TNAX 160432 TR-25	h_{max}	0,15	0,12	0,10	0,10	0,08	0,08
			v_c	340-380	280-340	240-280	210-240	180-210	140-180
	TN.1604.018.03 SKY77	TNAX 160441 TR-25	h_{max}	0,15	0,12	0,10	0,10	0,08	0,08
			v_c	340-380	280-340	240-280	210-240	180-210	140-180

WSP-FORM TC | TN

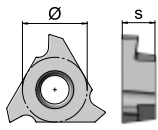

TC TN				
AS	Ø		s	
3	11	16	03	04
	6,35	9,52	3,2	4,76

Zuteilung Zerspanparameter zu den AV Materialgruppen

				NE-Metalle		
Artikel		Bezeichnung		E82	E81	E80
TC..1103..	TC.1103.030.06 SKY77	TCAX 110316 TR-25	h_{max}	0,15	0,12	0,10
			v_c	650-1000	450-650	280-450
	TC.1103.030.05 SKY77	TCAX 110318 TR-25	h_{max}	0,15	0,12	0,10
			v_c	650-1000	450-650	280-450
	TC.1103.030.04 SKY77	TCAX 110321 TR-25	h_{max}	0,15	0,12	0,10
			v_c	650-1000	450-650	280-450
	TC.1103.030.03 SKY77	TCAX 110326 TR-25	h_{max}	0,15	0,12	0,10
			v_c	650-1000	450-650	280-450
TN..1604..	TN.1604.018.01 SKY77	TNAX 160426 TR-25	h_{max}	0,18	0,15	0,11
			v_c	650-1000	450-650	280-450
	TN.1604.018.02 SKY77	TNAX 160432 TR-25	h_{max}	0,18	0,15	0,11
			v_c	650-1000	450-650	280-450
	TN.1604.018.03 SKY77	TNAX 160441 TR-25	h_{max}	0,18	0,15	0,11
			v_c	650-1000	450-650	280-450

WSP

TC..1103...	08B.2506.7991	TX208
TN..1604...	08B.0375.7991	TX208