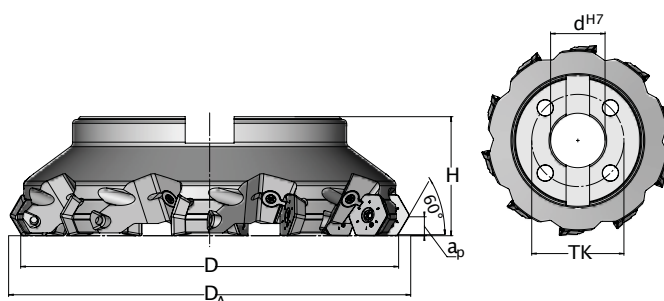

FRESE A SPIANARE **HD60****NEWT**ool

Utilizzo universale su ghisa e acciaio  
 Superficie di ottima qualità  
 Sistema variabile con cuneo per utilizzo  
 su materiali a truciolatura lunga e corta

**HD60**  
 frese a manicotto

articolo	D	D <sub>A</sub>	d <sup>H7</sup>	H	z <sub>eff</sub>	a <sub>p</sub>	cuneo	TK	RI	Kg	INS
03H.1263.100	125	137,8	40	63	7	10	si	-	no	3,23	HD..2207.N
03H.1663.100	160	172,8	40	63	9	10	si	66,7	no	5,26	HD..2207.N
03H.2063.100	200	212,8	60	63	10	10	si	101,6	no	8,57	HD..2207.N

set cuneo



08Z.0000.358

08K.1008.010

08Z.0000.093

TX225

# FORMA INS. HD

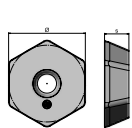
**HD**

AS	Ø	s
6	22	07
	22	7

Parametri di taglio consigliati  
rispetto ai gruppi di materiali AV

	articolo	descrizione	Suggerimenti $a_e$ 0,7 x D	acciaio						
				A22	A21	A20	A19	A18	A17	A16
HD..2207..	HD.2207.002.01 SKY77	HDHW 2207M0 SN-23	$h_{max}$	0,65	0,60	0,55	0,50	0,45	-	-
			$v_c$	280-320	240-280	210-240	180-210	140-180	-	-
HD..2207..	HD.2207.004.01 SKY77	HDHT 2207M0 SN-28	$h_{max}$	-	-	0,50	0,45	0,40	0,35	0,30
			$v_c$	-	-	210-240	180-210	140-180	110-140	80-110

	articolo	descrizione	Suggerimenti $a_e$ 0,7 x D	ghisa					
				D21	D20	D19	D18	D17	D16
HD..2207..	HD.2207.002.01 SKY77	HDHW 2207M0 SN-23	$h_{max}$	0,65	0,60	0,55	0,50	0,45	-
			$v_c$	280-320	260-290	240-280	210-240	180-210	-
HD..2207..	HD.2207.002.01 NERO <sup>2</sup> 77	HDHW 2207M0 SN-23	$h_{max}$	0,65	0,60	0,55	0,50	0,45	-
			$v_c$	300-340	280-320	240-280	210-240	180-210	-
HD..2207..	HD.2207.002.01 CAN <sup>2</sup> 77	HDHW 2207M0 SN-23	$h_{max}$	0,65	0,60	0,55	0,50	0,45	-
			$v_c$	320-380	300-340	260-300	210-240	180-210	-
HD..2207..	HD.2207.004.01 SKY77	HDHT 2207M0 SN-28	$h_{max}$	-	-	-	0,45	0,40	0,35
			$v_c$	-	-	-	210-240	180-210	140-180

**INS**

HD..2207...



08B.0514.7991



TX220