

HIGH FEED MILLING CUTTERS

SP18

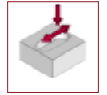

High feed milling cutter with high precision interchangeable carbide head system
 Optimal power transmission through cross or star drive keys
 Extreme stability for a long tool life

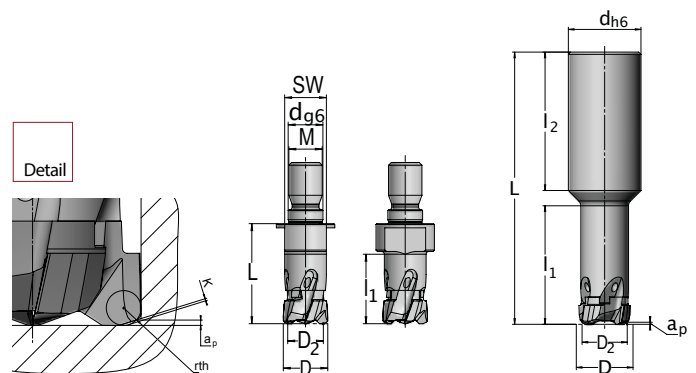

SP18 Smooth shank tool holders									INS
Article	D	dh6	L	l1	l2	lc	kg		
20G.20.1412.01	16	20	80	27	50	yes	0.15	ECK1612.R	
20G.20.1422.01	16	20	95	42	50	yes	0.17	ECK1612.R	
20G.20.1432.01	16	20	120	67	50	yes	0.20	ECK1612.R	
20G.20.1723.01	20	20	100	48	50	yes	0.26	ECK2012.R	
20G.32.2125.01	25	32	120	52	61	yes	0.53	ECK2512.R	
20G.32.2135.01	25	32	150	82	61	yes	0.61	ECK2512.R	

SP18 Screw-in tool holders									INS
Article	D	dg6	L	l1	M	SW	lc	kg	
20K.12.1412.01	16	12.5	36	25	12	15	yes	0.15	ECK1612.R
20K.16.2115.01	25	17	40	29	16	24	yes	0.16	ECK2512.R

Data Interchangeable heads ECK									
Article	D	D2	z _{eff}	a _p	r _{th}	K	Ramp	Weight in g	
EC.K1612.42.02 SKY77	16	12.8	4	0.8	2.0	0.26	3.8°	15.0	
EC.K2012.53.01 SKY77	20	13.5	5	0.75	2.5	0.29	3.1°	26.0	
EC.K2512.45.01 SKY77	25	19.9	4	0.8	2.0	0.26	2.3°	35.7	
EC.K2512.65.01 SKY77	25	17.9	6	0.8	2.5	0.41	2.3°	38.5	

INTERCHANGEABLE HEADS **EC**

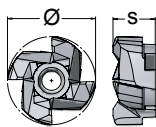

ECK				ECK			ECK		
AS	Ø		s	AS	Ø	s	AS	Ø	s
4	16	25	12	5	20	12	6	25	12
	16	25	12		20	12		25	12

Matching of machining parameters
with the AV material groups

				Steel						
Article		Designation		A22	A21	A20	A19	A18	A17	A16
ECK1612..	EC.K1612.42.02 SKY77	ECK 161210 TR-25	h_{max}	0.8	0.8	0.65	0.6	0.55	0.5	0.45
			v_c	280-320	240-280	210-240	180-210	140-180	110-140	80-110
ECK2012...	EC.K2012.53.01 SKY77	ECK 201210 TR-28	h_{max}	0.7	0.7	0.6	0.55	0.5	0.45	0.4
			v_c	280-320	240-280	210-240	180-210	140-180	110-140	80-110
ECK2512...	EC.K2512.45.01 SKY77	ECK 251210 TR-25	h_{max}	1.0	0.85	0.85	0.8	0.75	0.7	0.55
			v_c	280-320	240-280	210-240	180-210	140-180	110-140	80-110
	EC.K2512.65.01 SKY77	ECK 251210 TR-28	h_{max}	0.65	0.65	0.55	0.5	0.45	0.4	0.35
			v_c	280-320	240-280	210-240	180-210	140-180	110-140	80-110

				Cast iron					
Article		Designation		D21	D20	D19	D18	D17	D16
ECK1612..	EC.K1612.42.02 SKY77	ECK 161210 TR-25	h_{max}	0.8	0.8	0.7	0.6	0.5	0.45
			v_c	340-380	280-340	240-280	210-240	180-210	140-180
ECK2012...	EC.K2012.53.01 SKY77	ECK 201210 TR-28	h_{max}	0.75	0.75	0.65	0.55	0.55	0.5
			v_c	340-380	280-340	240-280	210-240	180-210	140-180
ECK2512...	EC.K2512.45.01 SKY77	ECK 251210 TR-25	h_{max}	1.0	1.0	0.85	0.85	0.75	0.7
			v_c	340-380	280-340	240-280	210-240	180-210	140-180
	EC.K2512.65.01 SKY77	ECK 251210 TR-28	h_{max}	0.75	0.75	0.65	0.55	0.55	0.5
			v_c	340-380	280-340	240-280	210-240	180-210	140-180

INS

ECK1612...	08B.3512.7991	TX215
ECK2012...	08B.0516.7991	TX220
ECK2512...	08B.0520.7991	TX220